

Bullet

PATENT
PENDING

Taking cantilever gates to new levels of simplicity, these innovative mono carriages are the easiest and fastest to install ever.

A few simple steps to install:

- The distance between the wheel units can be adjusted to adapt the carriage to **different gate sizes**.
- A **single carriage** to align and fix for very rapid installation
- **Just four bolts** to adjust for precise alignment

Portando i cancelli autoportanti a nuovi livelli di semplicità, questi carrelli innovativi sono in assoluto i più facili e veloci da installare.

Pochi semplici passaggi per l'installazione:

- *La distanza tra le ruote può essere regolata per adattare il carrello alle **diverse dimensioni** dei cancelli.*
- *Un **unico carrello** da allineare e fissare per un'installazione veloce*
- ***Bastano 4 dadi** per regolare il carrello*





The Bullet mono-carriage cantilever system

Il mono-carrello Bullet

- **EASY AND FAST.** The ease of installing a single mono-carriage insures an extremely rapid operation.
- **ADJUSTABLE.** The mono-carriage is adjustable in length allowing for many different gate size and weight installations.
- **ALIGNEMENT.** The alignment between the wheel units is always perfect without guides or accessories.
- **LOW INSTALLATION.** Usin the sunken foundation plate the entire carriage can be installed lower than ground level.
- **FACILE E VELOCE.** Il semplice posizionare un unico carrello consente un'installazione facile e veloce
- **REGOLABILE.** La distanza regolabile tra le ruote rende il monocarrello adatto a differenti lunghezze e pesi di cantilever.
- **ALLINEAMENTO.** L'allineamento tra le ruote è sempre garantito senza l'ausilio di dime o altri accessori.
- **INSTALLAZIONE RIBASSATA.** Mediante la base di contenimento è possibile abbassare il cancello mantenendo un design pulito.



Support for rack *Attacchi per cremagliera*



ART.

264

266

Tracks / Binari



ART.

CGS-345M

CGS-345P

CGA-345M

CGA-345P

Racks / Cremagliere



ART.

260-22x22

262-30x12

261-26x20

End cup / Incontro



ART.
CG-25M
CG-25P
CG-30M
CG-30P
CG-35P



Bottom end cup
Incontro inferiore



ART.
CGS-346M
CGS-346P

Guide plates / Piastre



ART.
CG-251
252-200
232-30
232-40



Tension bar / Tirante



ART.
CG-40

Carriages / Carrelli



ART.
CGS-600.16 M
CGA-600.10 M
CGS-600.16 P
CGA-600.10 P



Fixing template / Fissaggio



ART.
CG-60M
CG-60P
CG-06M
CG-06P
CG-65

End stopper for monorail
Terminale per monorotaia



ART.
CGS-347M
CGS-347P
CGA-347M
CGA-347P
CG-20M
CG-20P
CGA-20M
CGA-20P
CG-21M
CG-21P

Wall bracket
Staffa fissaggio a muro



ART.
CG-15M
CG-15P

BULLET

The adjustable, precise, rapid installation
mono carriage. Configuration made eas .
Un unico carrello per dimensioni diverse.
Preciso, regolabile e di rapida installazione.

5 nylon wheel carriage head with new
generation silent sealed bearings

*5 ruote in nylon con cuscinetti schermati
e silenziosi di nuova generazione*

CGA-600.10 M
ALUMINIUM

Internationally patented carriage body structure

Struttura carrello con brevetto internazionale

8 Wheel carriage head with new generation silent sealed bearings

8 ruote con cuscinetti schermati e silenziosi di nuova generazione

The disalignment between the four center wheels and the four external wheels allows the full load of the gate to be exchanged from the external wheels to the internal wheels when opening and closing

Il disallineamento tra le ruote centrali e quelle esterne consente di spostare il carico del cancello in maniera alternata prima sulle ruote centrali e poi su quelle esterne nel momento dell'apertura e della chiusura del cancello

CGS-600.16 M



Thanks to the rotation pin the carriage is automatically balanced distributing the load between the wheels

Grazie ai perni di rotazione il carrello si autobilancia distribuendo il carico tra tutte le ruote

Bullet. Simplified and precise installation

Bullet. Installazione semplificata e precisa

Select the required carriage length and simply position the mono carriage.

Scegli la posizione adatta delle ruote e semplicemente posiziona il monocarrello

Bullet MINI



Bullet PICCOLO

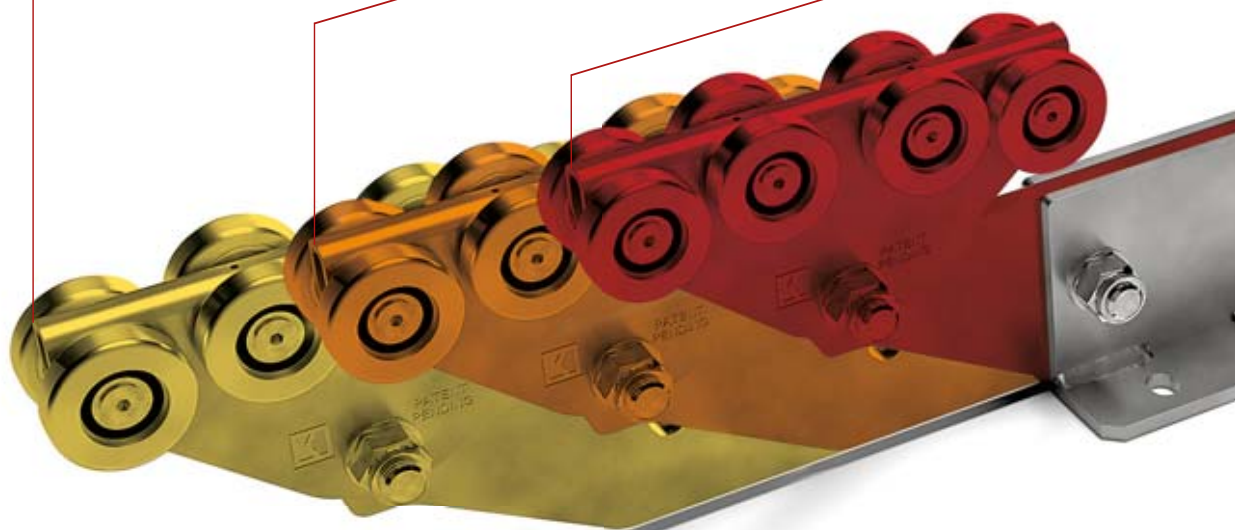

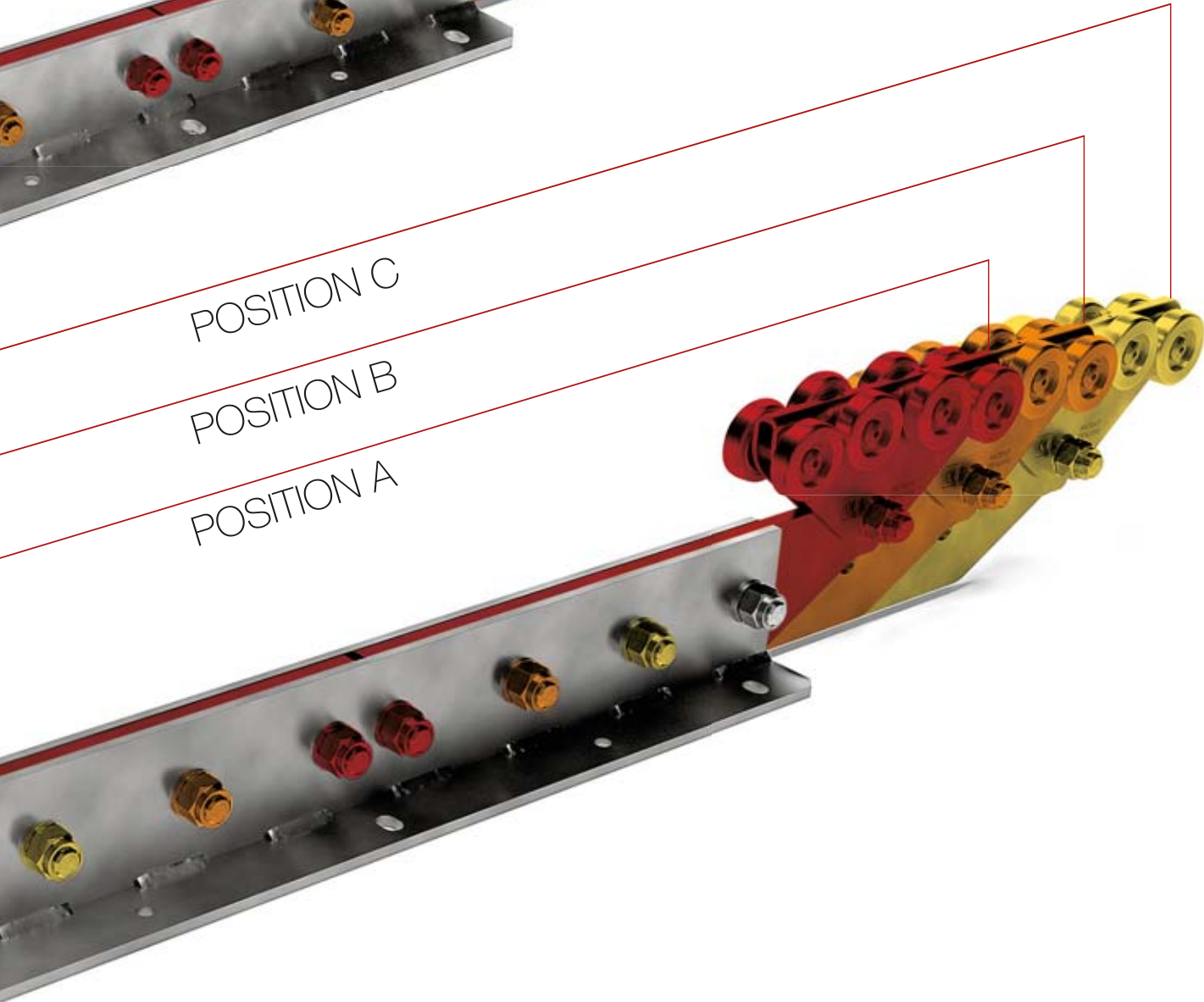
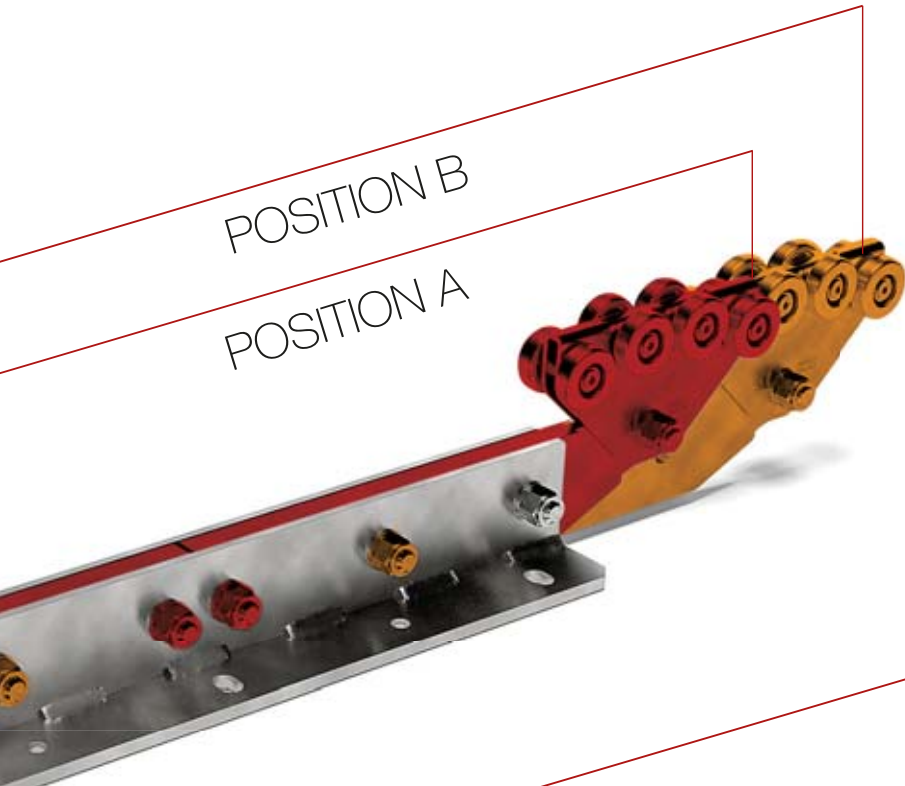

BULLET

Bullet MINI PATENT PENDING

CGS-600.16 M

Adjustable Mini cantilever carriage with 16 wheels, Bullet system

Carrello Bullet Mini regolabile a 16 ruote

Chariot autoportant ajustable Mini avec 16 roues, système Bullet

Einstellbar Mini Laufwagen mit 16 Rädern, Bullet System

Carro ajustable autoportante Mini con 16 ruedas, sistema Bullet

Регулируемая 16-ти колесная тележка Mini, система Bullet

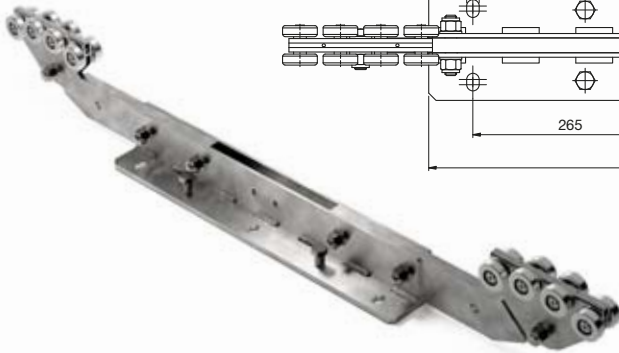
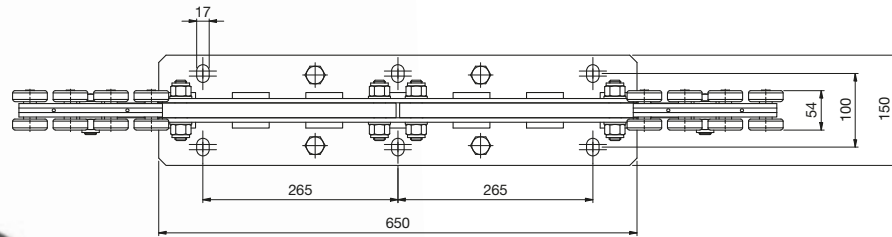
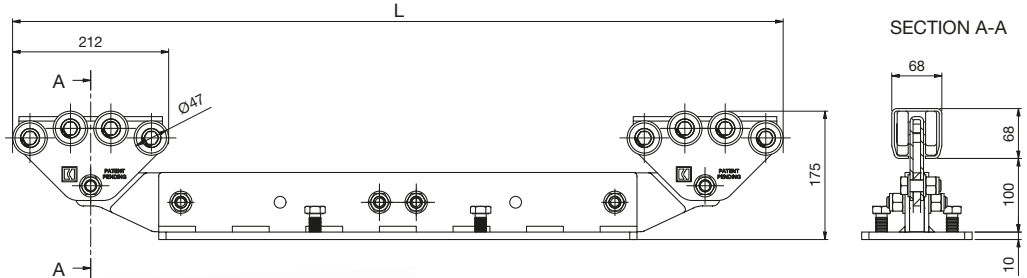

CODE	ART.	Size	L position A	L position B	Box info	
					Pcs per pack	Kg
10130400 001	CGS-600.16 M	Mini	1047	1317	1	29

Minimum dimensions of the reinforced concrete casting
Dimensioni minime getto cemento armato

FOUNDATION CALCULATOR / CALCOLO FONDAZIONE

Weight (Kg)	POSITION A			POSITION B		
	L=2 m FA (m)	L=3 m FA (m)	L=4 m FA (m)	L=5 m FA (m)	L=6 m FA (m)	L=7 m FA (m)
100	1.1	1.1	1.1	1.1	1.1	1.2
150	1.1	1.1	1.1	1.2	1.3	1.4
200	1.1	1.1	1.2	1.4	1.5	1.7
250	1.1	1.2	1.4	1.6		
300	1.1	1.3	1.5			
350	1.3	1.5	1.7			
400	1.4	1.7				
450	1.5	1.8				
500	1.7					
550	1.8					
600	2.0					

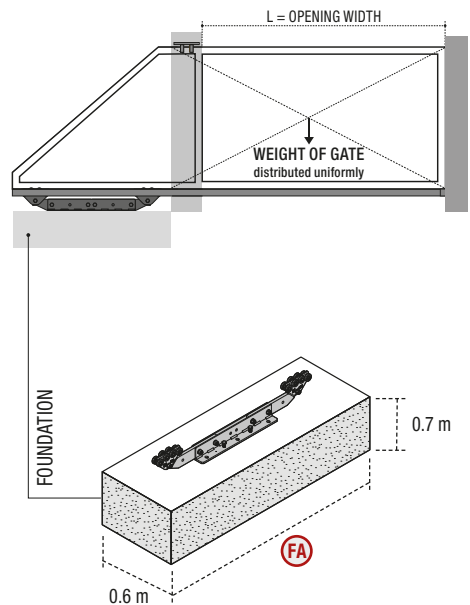

With sunken fixing plate the minimum length of A is 1.5 m
In caso di utilizzo della vasca di appoggio la misura FA minima è 1,5 m

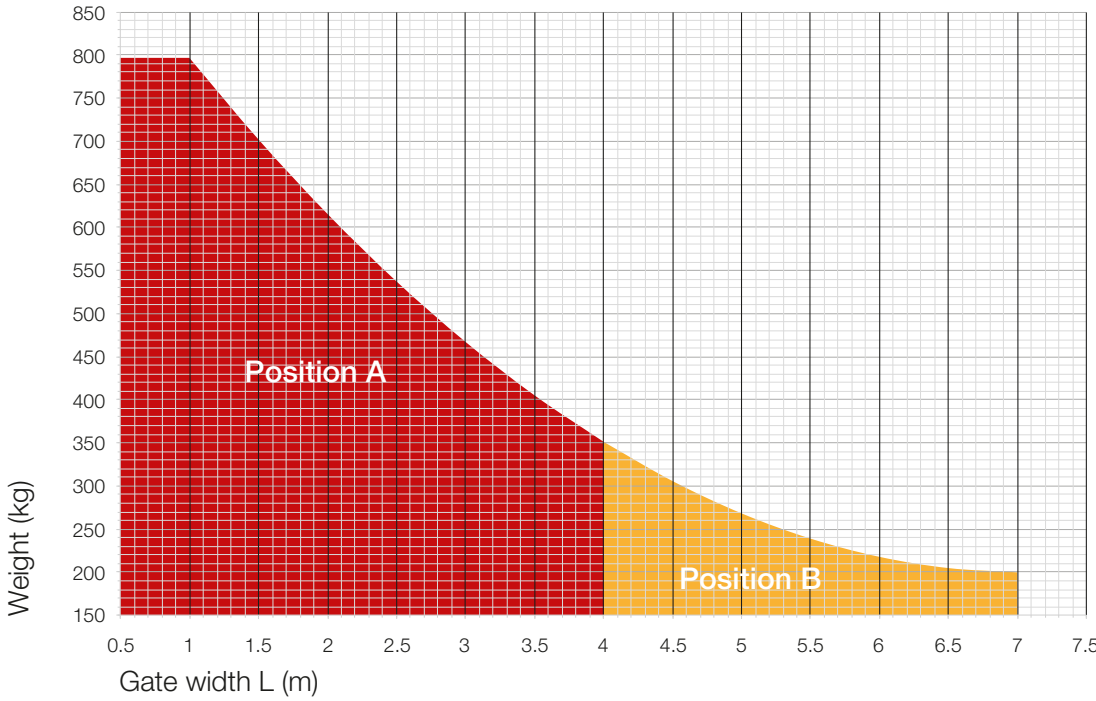

Bullet MINI - Position A

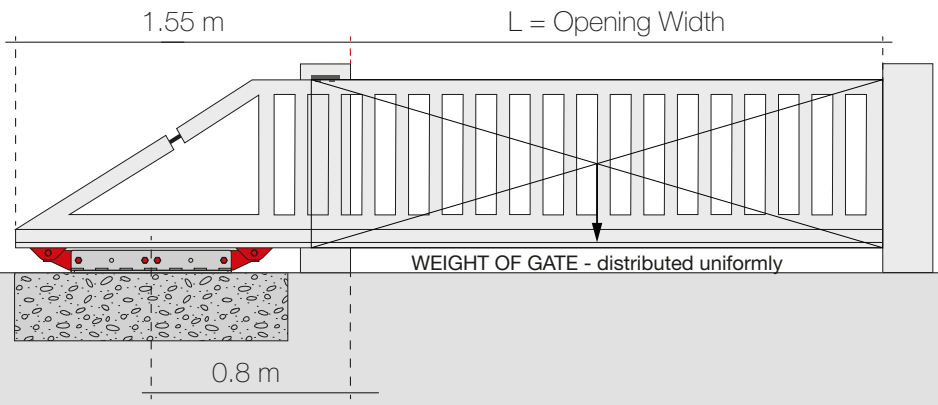
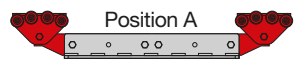

Bullet MINI - Position B

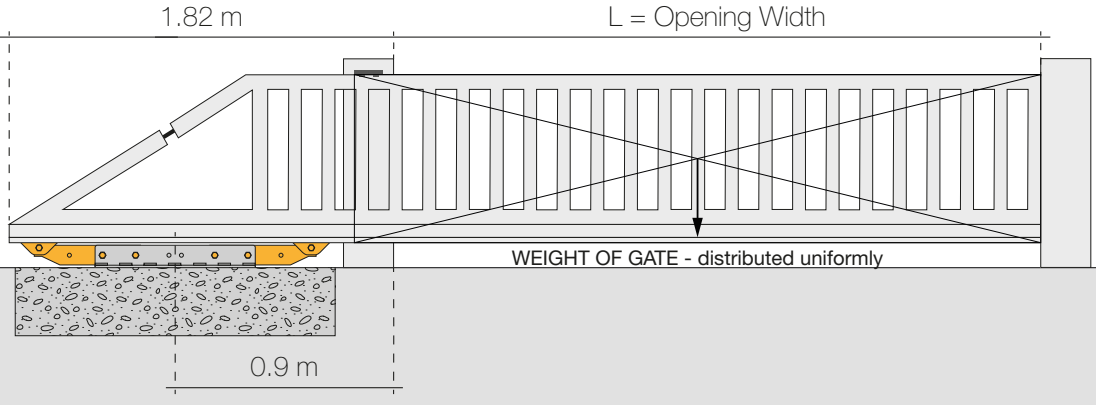
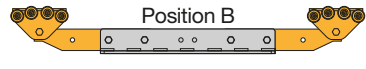

The automation must be installed at the centre of the mono carriage
 L'automazione deve essere installata in corrispondenza dell'asse centrale del carrello

BULLET MINI ALUMINIUM

Bullet PICCOLO PATENT PENDING

CGS-600.16 P

Adjustable Piccolo cantilever carriage with 16 wheels, Bullet system

Carrello Bullet Piccolo regolabile a 16 ruote

Chariot autoportant adjustable Piccolo avec 16 roues, système Bullet

Einstellbar Piccolo Laufwagen mit 16 Rädern, Bullet System

Carro ajustable autoportante pequeño con 16 ruedas, sistema Bullet, por puertas en aluminio

Регулируемая 16-ти колесная тележка Piccolo, система Bullet

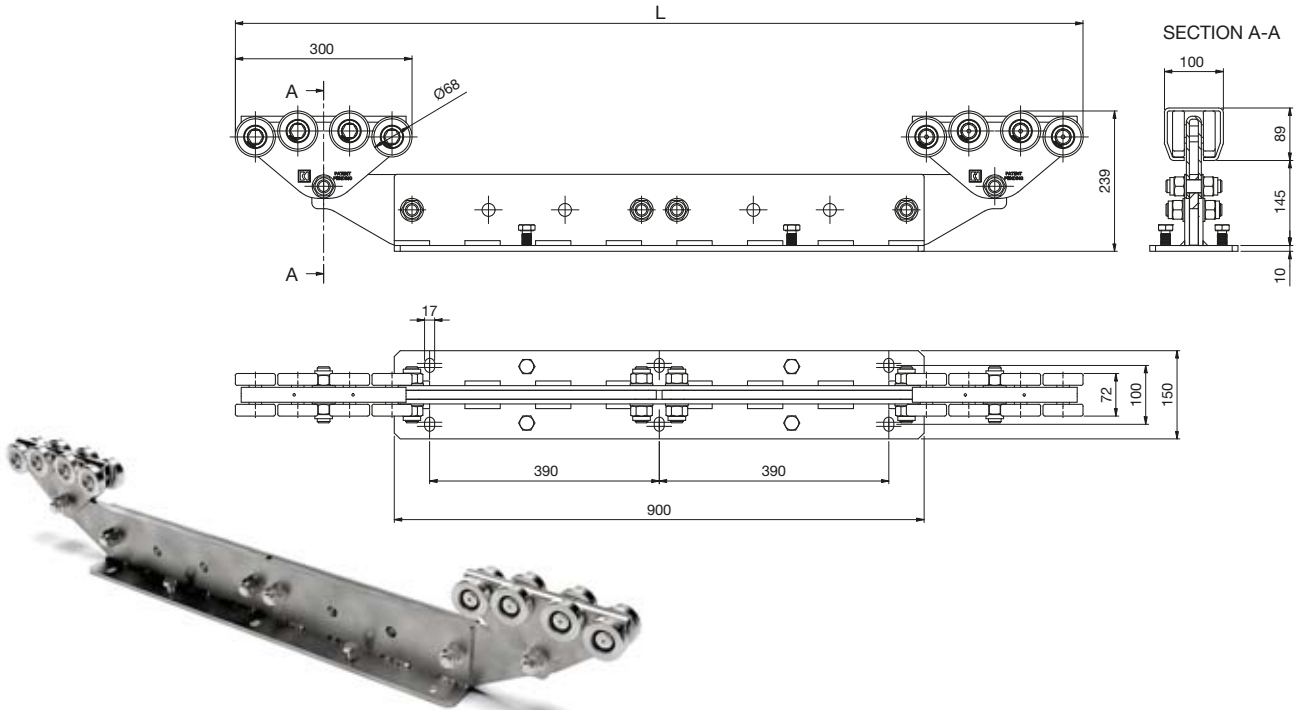

CODE	ART.	Size	L position A	L position B	L position C	Box info	
						Pos per pack	Kg
10130401 001	CGS-600.16 P	Piccolo	1440	1700	1960	1	54.5

Minimum dimensions of the reinforced concrete casting

Dimensioni minime getto cemento armato

FOUNDATION CALCULATOR / CALCOLO FONDAZIONE

Weight (Kg)	POSITION A		POSITION B			POSITION C		
	L=2 m	L=3 m	L=4 m	L=5 m	L=6 m	L=7 m	L=8 m	
	FA (m)	FA (m)	FA (m)	FA (m)	FA (m)	FA (m)	FA (m)	
100	1.3	1.3	1.3	1.3	1.3	1.3	1.3	
150	1.3	1.3	1.3	1.3	1.3	1.3	1.3	
200	1.3	1.3	1.3	1.3	1.3	1.3	1.5	
250	1.3	1.3	1.3	1.3	1.3	1.5	1.6	
300	1.3	1.3	1.3	1.3	1.5	1.6	1.8	
350	1.3	1.3	1.3	1.4	1.6	1.8	2.0	
400	1.3	1.3	1.4	1.6	1.7	1.9		
450	1.3	1.3	1.5	1.7	1.9			
500	1.3	1.4	1.6	1.8				
550	1.3	1.5	1.7	2.0				
600	1.3	1.6	1.8					
650	1.4	1.7	2.0					
700	1.5	1.8	2.1					
750	1.6	1.9						
800	1.7	2.0						
850	1.8							
900	1.9							
950	2.0							
1000	2.1							
1050	2.3							

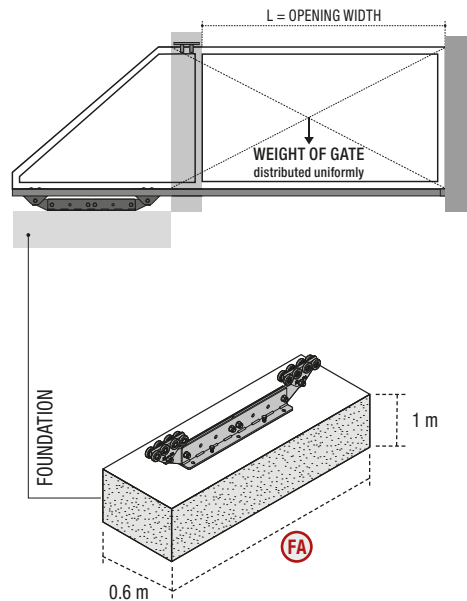

With sunken fixing plate the minimum length of A is 2m

In caso di utilizzo della vasca di appoggio la misura FA minima è 2 m

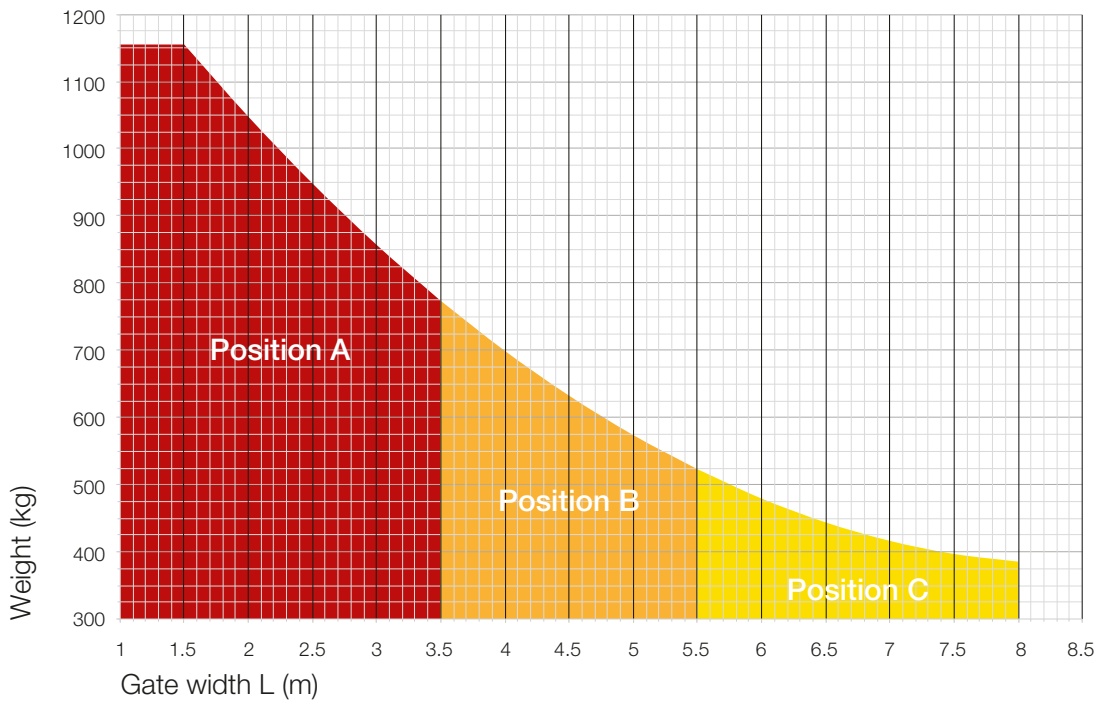

Bullet MINI - Position A

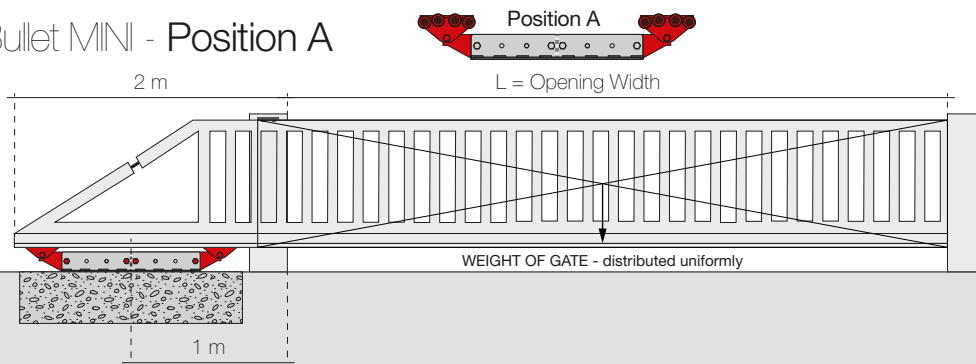

Bullet MINI - Position B

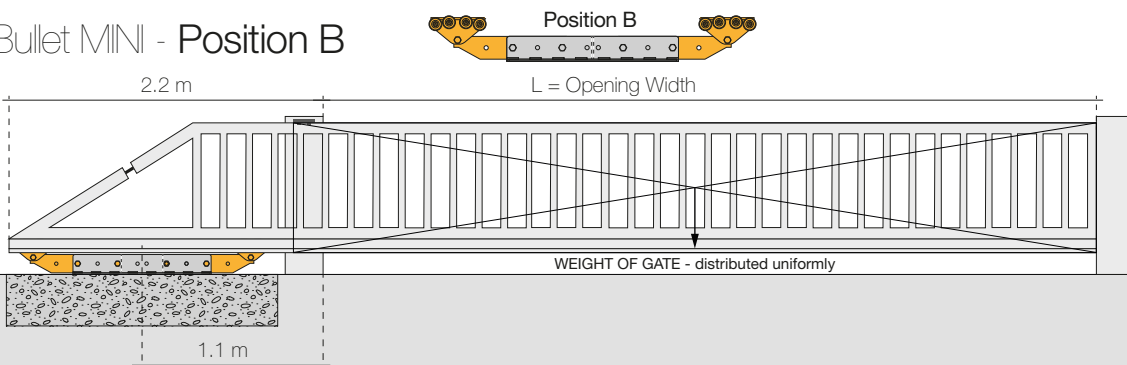

Bullet MINI - Position C

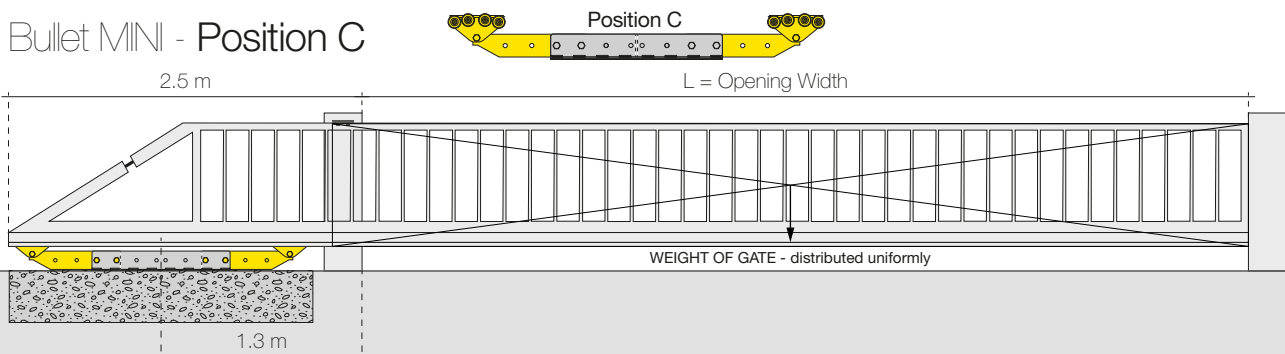

The automation must be installed at the centre of the mono carriage
L'automazione deve essere installata in corrispondenza dell'asse centrale del carrello

Bullet MINI Aluminium

PATENT PENDING

CGA-600.10 M

Adjustable Mini cantilever carriage with 10 wheels, Bullet system, for aluminium gate

Carrello Bullet Mini regolabile a 10 ruote per serie alluminio
Chariot autoportant adjustable Mini avec 10 roues, système Bullet, pour portail en aluminium
Einstellbar Mini Laufwagen mit 10 Rädern, Bullet System für die Aluminum Serie
Carro ajustable autoportante Mini con 10 ruedas, sistema Bullet, por puertas en aluminio
Регулируемая тележка Bullet Mini с 10 колесами для люминиевой серии

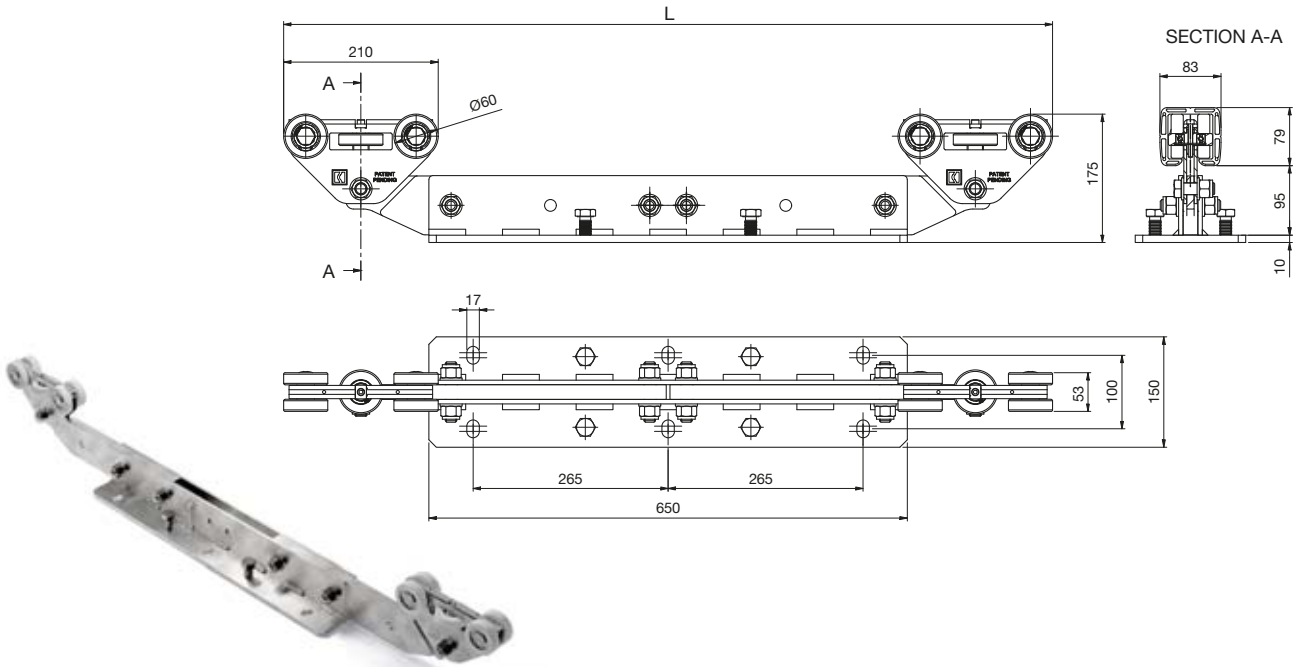

CODE	ART.	Size	L position A	L position B	Box info	
					Pcs per pack	Kg
10130402 001	CGA-600.10 M	Mini	1045	1315	1	27

Minimum dimensions of the reinforced concrete casting
 Dimensioni minime getto cemento armato

FOUNDATION CALCULATOR / CALCOLO FONDAZIONE

Weight (Kg)	POSITION A				POSITION B		
	L=2 m FA (m)	L=2.5 m FA (m)	L=3 m FA (m)	L=3.5 m FA (m)	L=4 m FA (m)	L=4.5 m FA (m)	L=5 m FA (m)
100	1.1	1.1	1.1	1.1	1.1	1.1	1.1
125	1.1	1.1	1.1	1.1	1.1	1.2	1.2
150	1.1	1.1	1.1	1.1	1.1	1.2	
175	1.1	1.1	1.1	1.2			
200	1.1	1.1					
225	1.1						

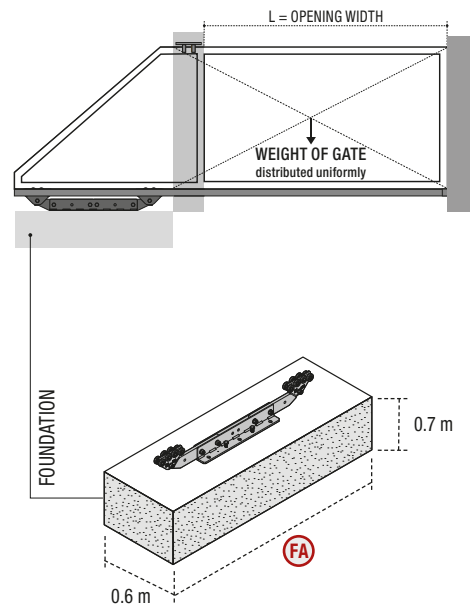

With sunken fixing plate the minimum length of A is 1.5 m
 In caso di utilizzo della vasca di appoggio la misura FA minima è 1.5 m

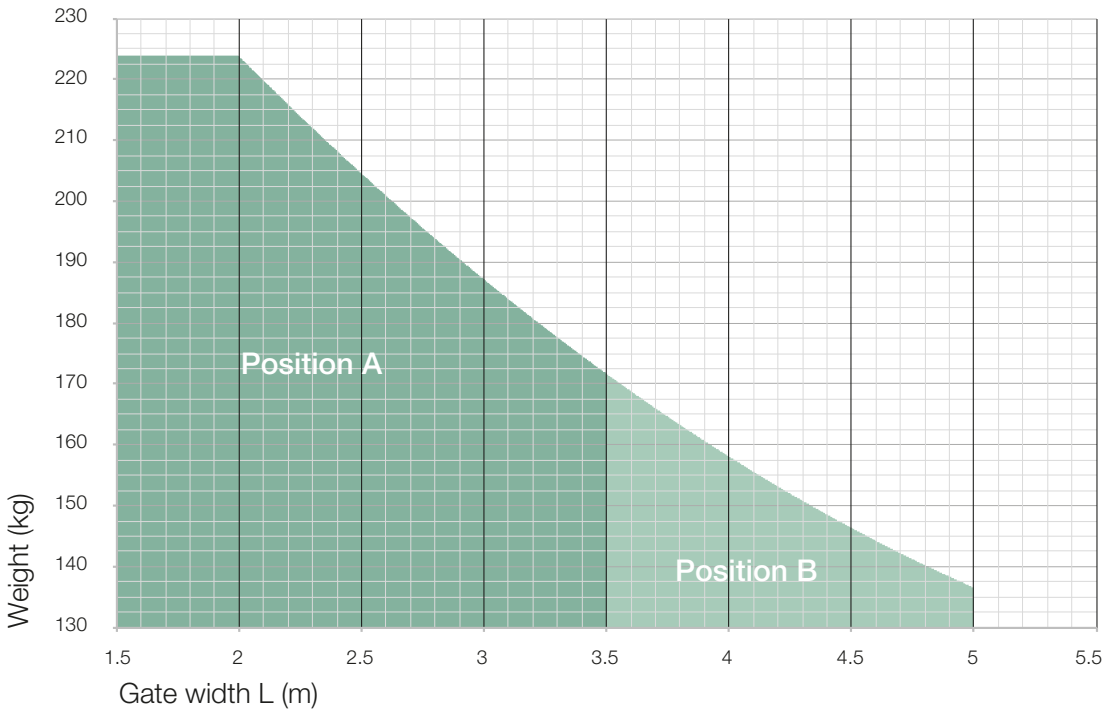

Bullet MINI - Position A

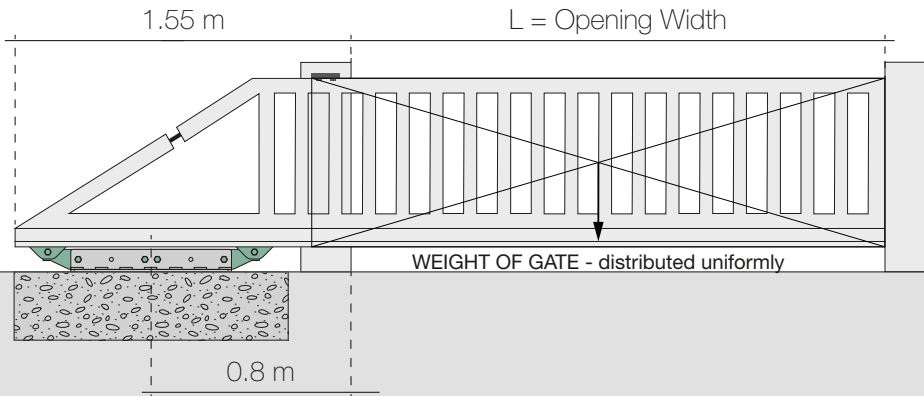

Bullet MINI - Position B

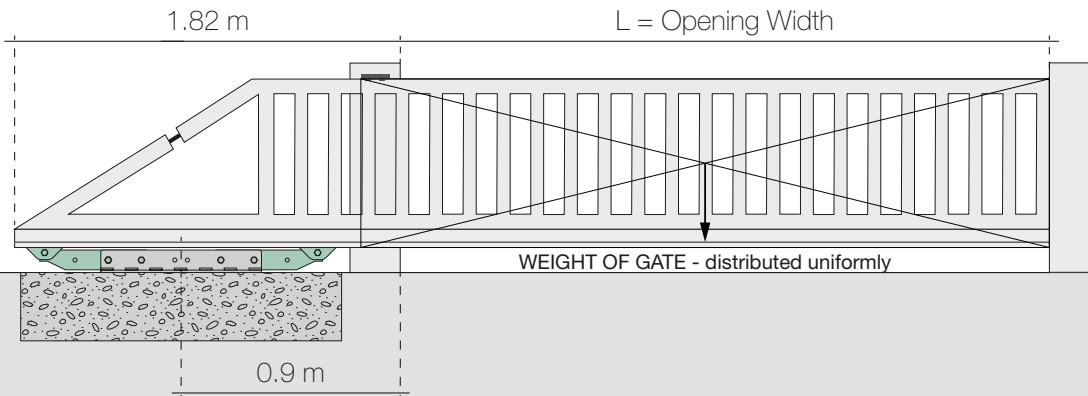

The automation must be installed at the centre of the mono carriage
L'automazione deve essere installata in corrispondenza dell'asse centrale del carrello

Bullet PICCOLO Aluminium

PATENT PENDING

CGA-600.10 P

Adjustable Piccolo cantilever carriage with 10 wheels, Bullet system, for aluminium gate

Carrello Bullet Piccolo regolabile a 10 ruote per serie alluminio

Chariot autoportant ajustable Piccolo avec 10 roues, système Bullet, pour portail en aluminium

Einstellbar Piccolo Laufwagen mit 10 Rädern, Bullet System für die Aluminum Serie

Carro ajustable autoportante pequeño con 10 ruedas, sistema Bullet, por puertas en aluminio

Регулируемая тележка Bullet Piccolo с 10 колесами для люминиевой серии

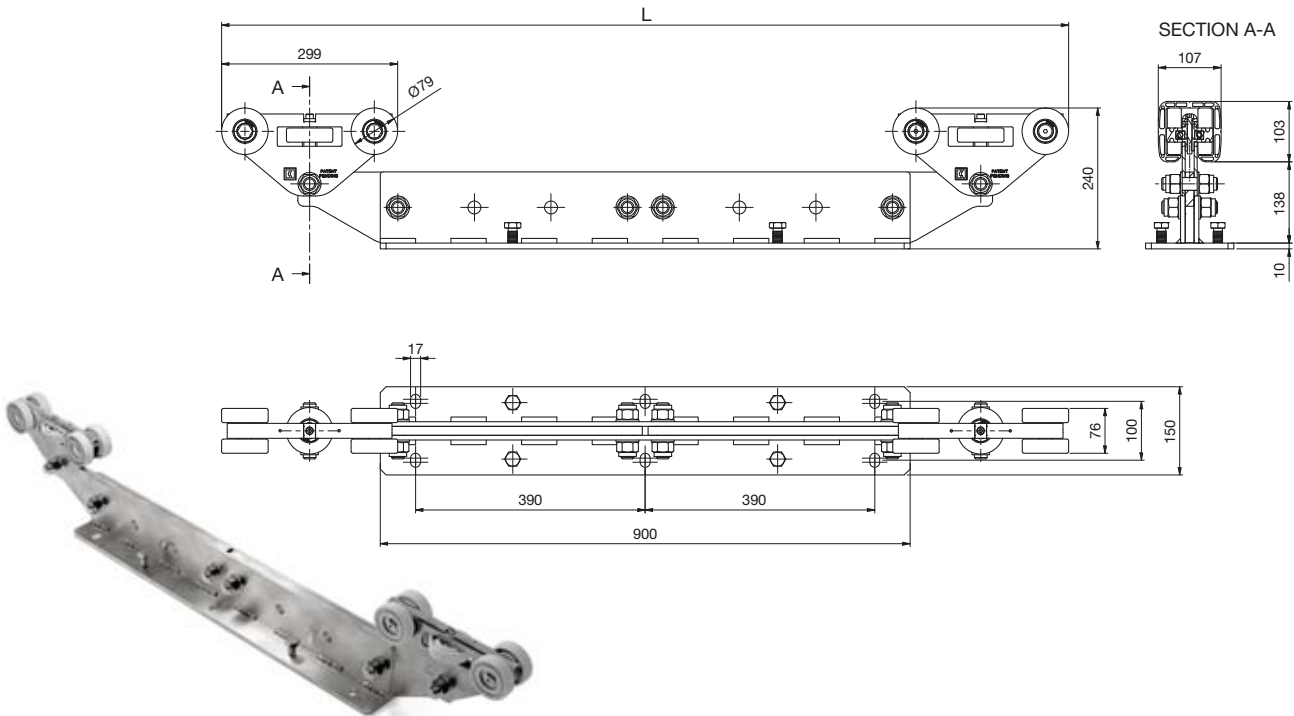

CODE	ART.	Size	L position A	L position B	L position C	Box info	
						Pcs per pack	Kg
10130403 001	CGA-600.10 P	Piccolo	1439	1699	1959	1	49

Minimum dimensions of the reinforced concrete casting

Dimensioni minime getto cemento armato

FOUNDATION CALCULATOR / CALCOLO FONDAZIONE

	POSITION A			POSITION B				POSITION C		
	L=2 m	L=2.5 m	L=3 m	L=3.5 m	L=4 m	L=4.5 m	L=5 m	L=5.5 m	L=6 m	
Weight (Kg)	FA (m)	FA (m)	FA (m)	FA (m)	FA (m)	FA (m)	FA (m)	FA (m)	FA (m)	
100	1.3	1.3	1.3	1.3	1.3	1.3	1.3	1.3	1.3	
125	1.3	1.3	1.3	1.3	1.3	1.3	1.3	1.3	1.3	
150	1.3	1.3	1.3	1.3	1.3	1.3	1.3	1.3	1.3	
175	1.3	1.3	1.3	1.3	1.3	1.3	1.3	1.3	1.3	
200	1.3	1.3	1.3	1.3	1.3	1.3	1.3	1.3	1.3	
225	1.3	1.3	1.3	1.3	1.3	1.3	1.3	1.3	1.3	
250	1.3	1.3	1.3	1.3	1.3	1.3	1.3	1.3	1.3	
275	1.3	1.3	1.3	1.3	1.3	1.3	1.3	1.3	1.3	
300	1.3	1.3	1.3	1.3	1.3					
325	1.3	1.3	1.3	1.3						
350	1.3	1.3	1.3							
375	1.3	1.3								
400	1.3	1.3								
425	1.3									

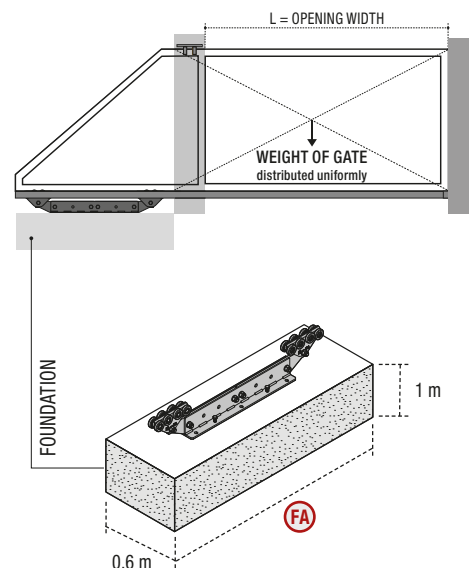

With sunken fixing plate the minimum length of A is 2m

In caso di utilizzo della vasca di appoggio la misura FA minima è 2 m

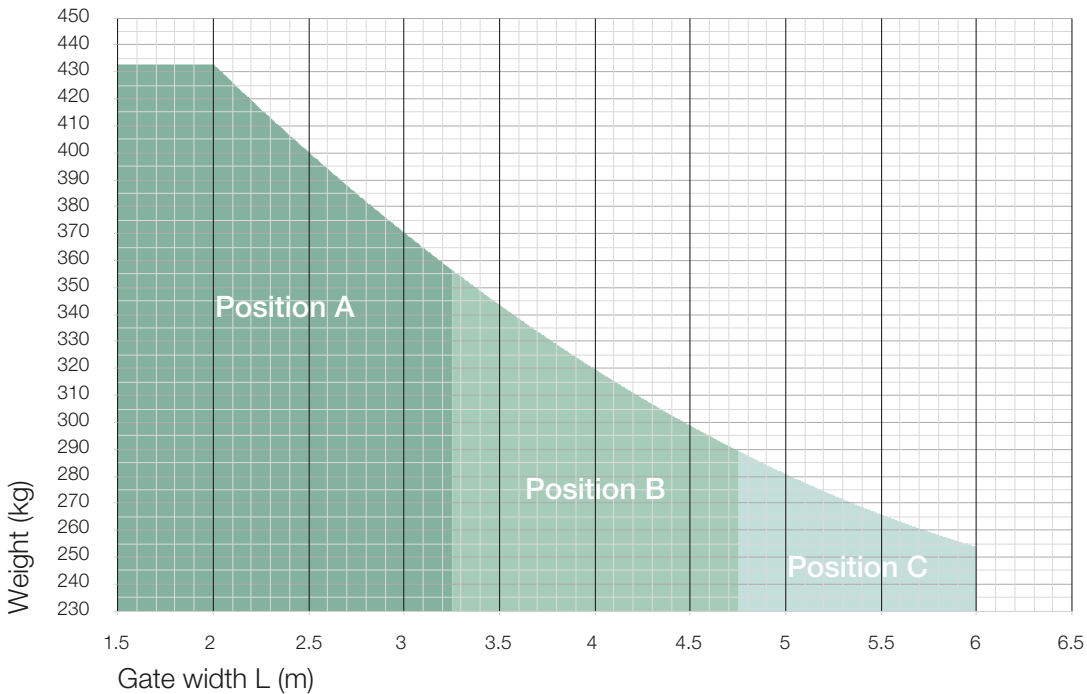

Bullet MINI - Position A

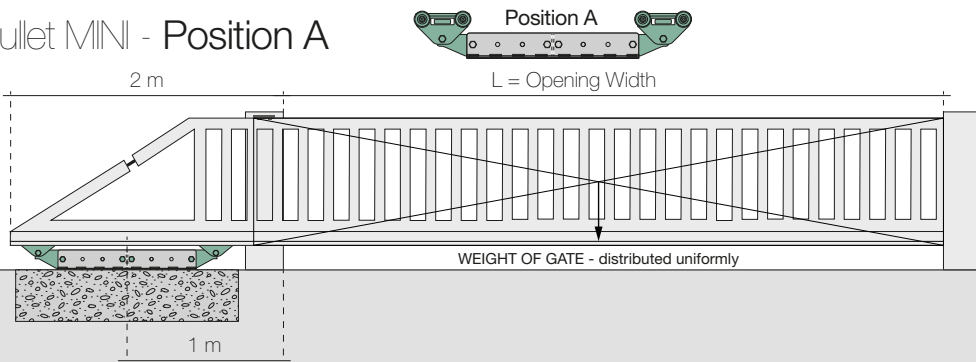

Bullet MINI - Position B

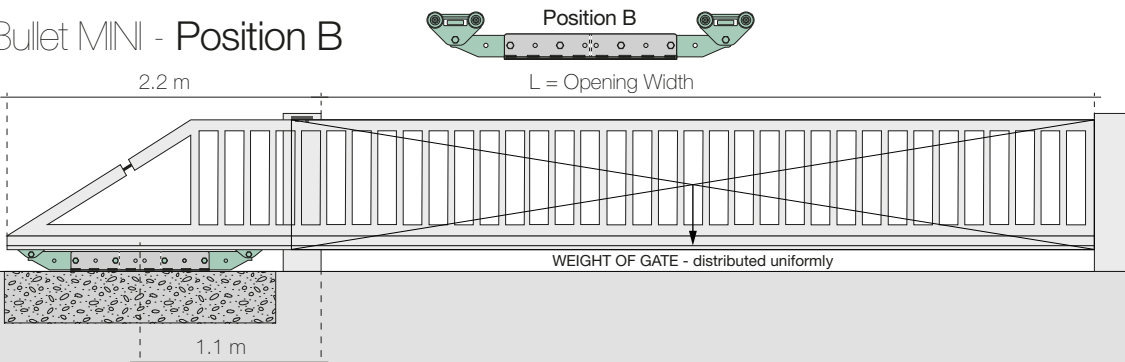

Bullet MINI - Position C

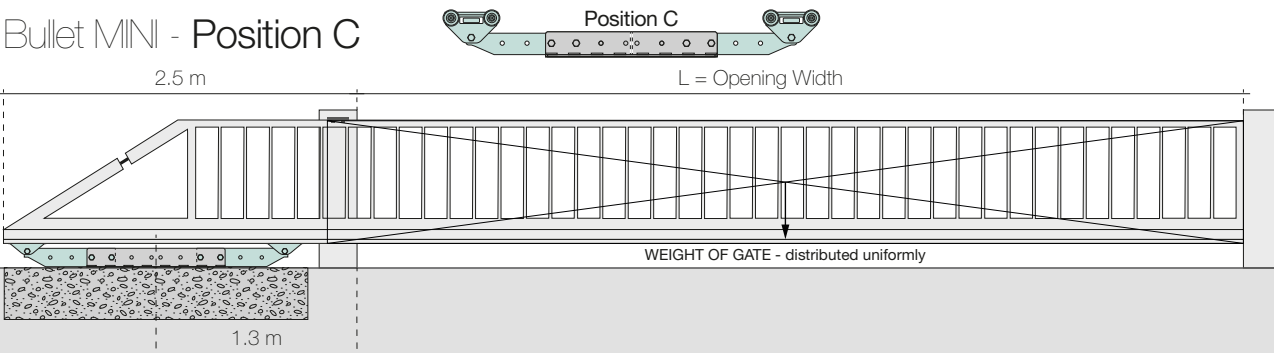

The automation must be installed at the centre of the mono carriage
L'automazione deve essere installata in corrispondenza dell'asse centrale del carrello

Classic fixing plat

Piastra di fissaggio

The Bullet mono carriage can be surface fixed to classic Comunello anchor plates for both the Mini size or the Piccolo size.

Il monocarrello Bullet può essere fissato in superficie utilizzando la piastra di fissaggio Comunello sia per il sistema Mini che per il sistema Piccolo.

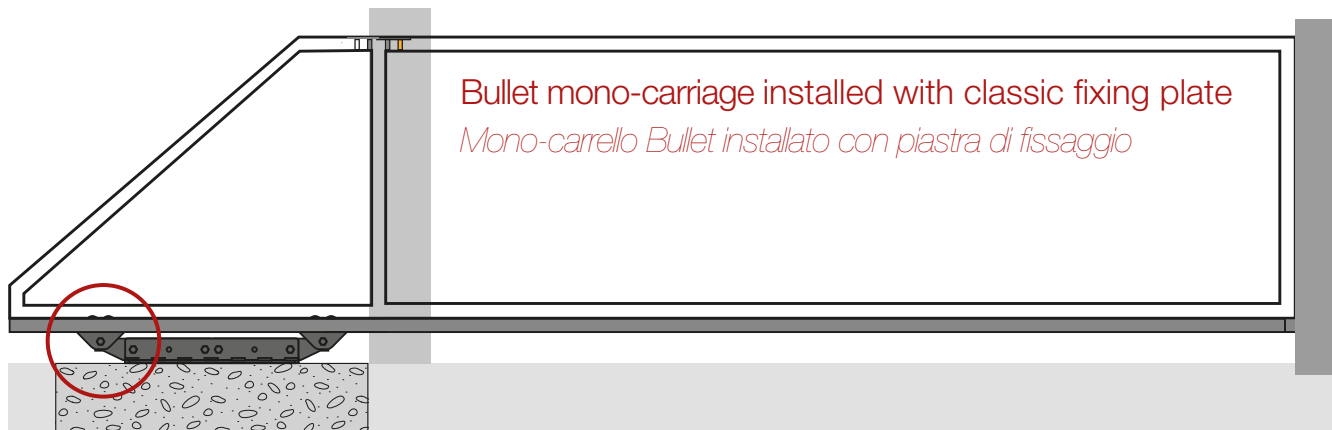

Bullet mono-carriage	H1 mm
CGS-600.16 M	110
CGS-600.16 P	155
CGA-600.16 M	105
CGA-600.16 P	148

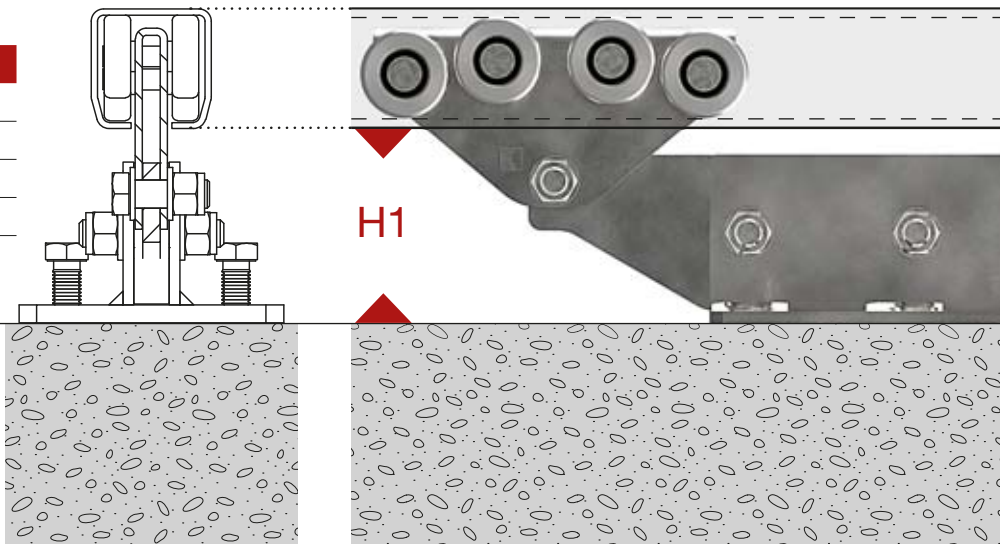

The sunken fixing plate for low clearance installations. *Base di contenimento carrello per un assetto ribassato*

The sunken fixing plate allows the entire system to be lowered up to 35 mm (Mini) or 70 mm (Piccolo) into the foundation block. This allows the gate to have a low clearance opening for architecturally minimal solutions or in the case of increased security. The sunken fixing plate is supplied with drainage holes that allow any rain water to be carried under ground and away from the foundations. All components have a high quality galvanised finish.

La vasca di fissaggio permette all'intero sistema di essere installato ad una profondità inferiore rispetto all'installazione superficiale, fino a 35 mm per il sistema Mini e fino a 70 mm per il sistema Piccolo. Questo garantisce al cancello un aspetto dall'assetto ribassato e di conseguenza una soluzione architettonica dal design minimal e inoltre una sicurezza maggiore. La vasca di fissaggio è dotata di fori che permettono all'acqua piovana di essere condotta sottoterra lontano dalle fondamenta. Tutti i componenti hanno una finitura galvanizzata di alta qualità.

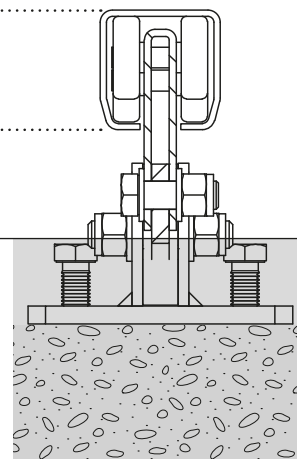
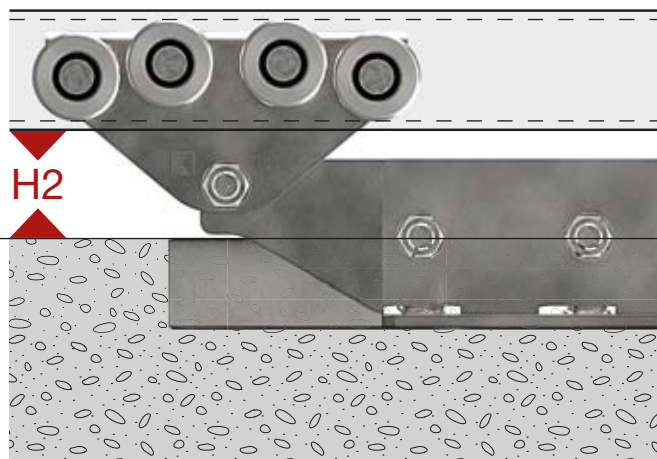
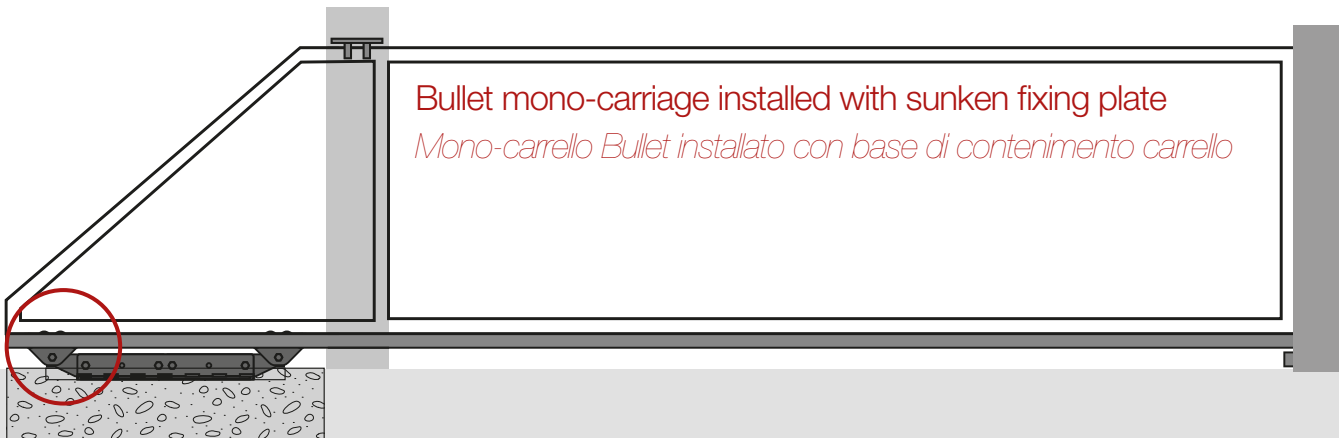

Bullet mono-carriage	H2 mm
CGS-600.16 M	75
CGS-600.16 P	86
CGA-600.16 M	70
CGA-600.16 P	79

BULLET

Bullet Accessories

CG-60

Sunken fixing plate for carriage, Bullet syste

Base di contenimento carrello Bullet

Plaque de fixation à encaisser pour chariot, système Bullet

Eindämmungsplatte für Laufwagen, Bullet System

Placa de fijación a cementar para carro, sistema Bullet

Заглубленная крепежная пластина для тележек, система Bullet



CODE	ART.	Size	A	B	C	D	E	F	Box info	
									Pcs per pack	Kg
10130800 001	CG-60 M	Mini	1120	40	335	265	1200	37	1	5.2
10130801 001	CG-60 P	Piccolo	1660	45	485	390	1750	71	1	9.6

Finishing: Galvanized / Zincato

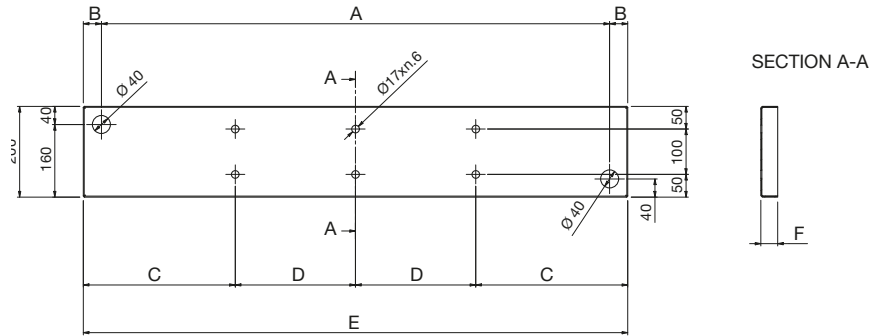

CG-06

Fixing plate for carriage, Bullet system

Contropiastra per fissaggio carrello Bullet

Plaque de fixation pour chariot, système Bullet

Klemmplatte für Laufwagen, Bullet System

Placa de fijación a cementar para carro, sistema Bullet

Контрплита для тележек, система Bullet



CODE	ART.	Size	A	B	Box info	
					Pcs per pack	Kg
10131015 001	CG-06 M	Mini	650	265	1	3.8
10131020 001	CG-06 P	Piccolo	900	390	1	5.2

Finishing: Galvanized / Zincato

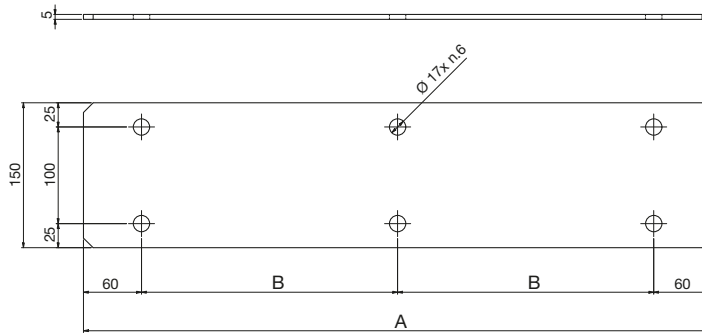

CG-65

Threaded tie rods for Mini and Piccolo carriages, Bullet system

Ancoranti per carrello Bullet Mini e Piccolo

Tirants filetés pour chariots Mini et Piccolo, système Bullet

Gewindestange für Mini und Piccolo Laufwagen, Bullet System

Ancajes roscados por carros Mini y Piccolo, sistema Bullet

Резьбовое анкерное крепление для тележек Mini и Piccolo, система Bullet



CODE	ART.	Size	Box info	
			Pcs per pack	Kg
10130515 001	CG-65	M&P	6	0.75

Finishing: Galvanized / Zincato

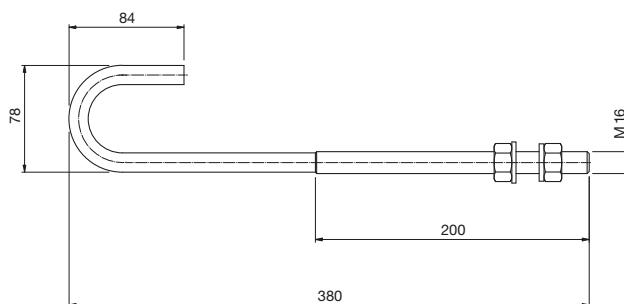

Bullet Compatible Aluminium Accessories

CGA-345

Monorail in extruded aluminium for cantilever gates
Monorotaia in alluminio estruso per cancelli auto-portanti
Rail en aluminium extrudé pour portails autoportants
Einfachschiene aus fließgepresstem Aluminium für selbsttragende Tore
Monocaril de aluminio extruido para puertas autoportantes
Монорельс из экструдированного алюминия для самонесущих ворот



CODE	ART.	Size	Finishing	A	B	C	H	L	Box info	
									Pcs per pack	Kg
10208001	CGA-345M	Mini	Raw	61	83	23	79	3000	1	12.00
10208003	CGA-345M	Mini	Raw	61	83	23	79	6000	1	24.00
10208005	CGA-345P	Piccolo	Raw	80.5	106.5	30	102.5	3000	1	16.00
10208007	CGA-345P	Piccolo	Raw	80.5	106.5	30	102.5	6000	1	32.00

Finishing: Aluminium / Alluminio

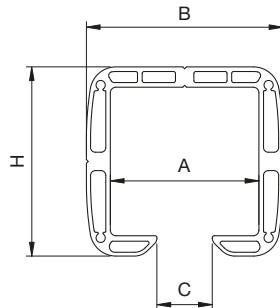

CGA-347

Nylon end wheel for aluminium monorail
Ruota terminale in nylon per monorotaia in alluminio
Galet d'extrémité en nylon pour rail en aluminium
Nylon-Endrolle für Einfachschiene aus Aluminium
Rueda terminal de nylon para monocaril de aluminio
Концевое колесо из нейлона для алюминиевого монорельса



CODE	ART.	Size	A	B	C	D	E	F	G	H	L	M	N	Box info	
														Pcs per pack	Kg
10705200 001	CGA-347M	Mini	119	83	83	∅ 66	119	16	7	79	45	32	15	2	2.10
10705205 001	CGA-347P	Piccolo	140	106.5	118	∅ 79	125	15	9.6	102.5	66	37	26	2	3.4

Finishing: Aluminium / Alluminio

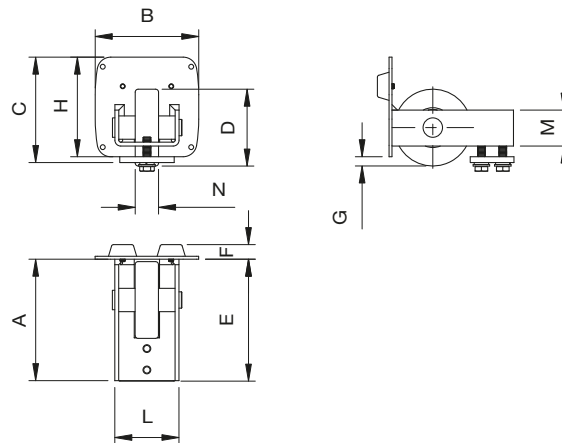

CGA-20

End stopper for aluminium monorail
Terminale per monorotaia in alluminio
Embout d'extrémité pour rail en aluminium
Endpfropfen für Einfachschiene aus Aluminium
Terminal para monocaril de aluminio
Наконечник для алюминиевого монорельса



CODE	ART.	Size	A	B	F	H	Box info	
							Pcs per pack	Kg
10707001 001	CGA-20M	Mini	16	83	12	79	2	0.44
10707005 001	CGA-20P	Piccolo	15	106.5	12	102.5	2	0.60

Finishing: Aluminium / Alluminio

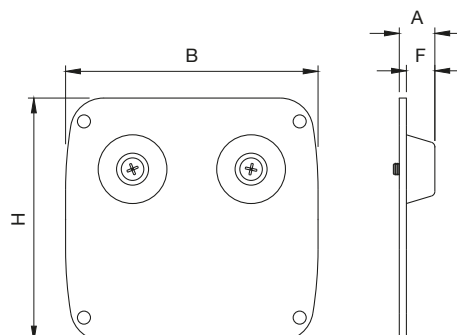

Compatible Cantilever Accessories

CGS-345

Monorail for cantilever gates
 Monorotaia per cancelli auto-portanti
 Rails pour portails autoportants
 Einfachschiene für selbsttragende Tore
 Monocarriil para puertas autoportantes
 Монорельс для самонесущих ворот



CODE	ART.	Size	Finishing	A	B	C	H	S	L	Box info	
										Pcs per pack	Kg
10207001	CGS-345M	Mini	Raw	48	68	23	68	3.5	3000	1	18.25
10207002	CGS-345M	Mini	Raw	48	68	23	68	3.5	6000	1	36.50
10207005	CGS-345P	Piccolo	Raw	66.5	100	33	89	5	3000	1	35.00
10207007	CGS-345P	Piccolo	Raw	66.5	100	33	89	5	6000	1	70.00
10207001 001	CGS-345M	Mini	Zinc	48	68	23	68	3.5	3000	1	18.25
10207002 001	CGS-345M	Mini	Zinc	48	68	23	68	3.5	6000	1	36.50
10207005 001	CGS-345P	Piccolo	Zinc	66.5	100	33	89	5	3000	1	35.00
10207007 001	CGS-345P	Piccolo	Zinc	66.5	100	33	89	5	6000	1	70.00

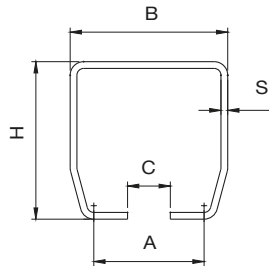

260

Square rack
 Cremagliera quadra
 Crémaillère carrée
 Viereckige Zahnstange
 Cremallera cuadrada
 Зубчатая рейка квадратная



CODE	ART.	Size	A	L	Box info	
					Pcs per pack	Kg
11400505 001	260-22x22	L=1000	22	1000	1	3.10

Finishing: Galvanized / Zincato

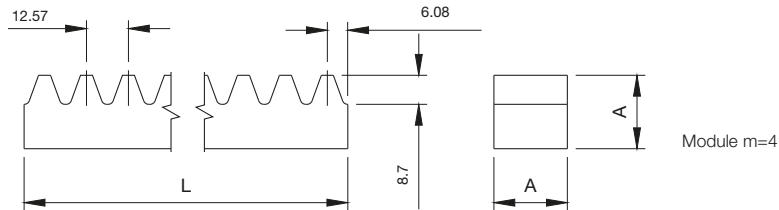

262

Rectangular rack 30x12 with holes
 Cremagliera Rettangolare 30x12 con fori
 Crémaillère rectangulaire 30x12 avec trous
 Rechteckige Zahnstange 30x12 mit Bohrungen
 Cremallera Rectangular 30x12 con agujeros
 Зубчатая рейка прямоугольная 30x12 с отверстиями

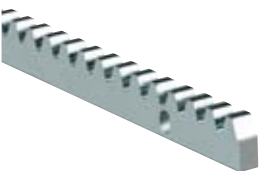

CODE	ART.	Size	L	Box info	
				Pcs per pack	Kg
11401005 001	262-30x12	L=1000	1000	1	2.40

Finishing: Galvanized / Zincato

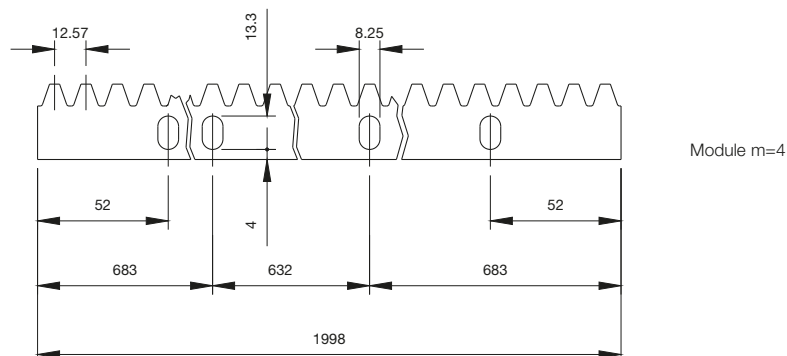

261

Nylon-rack with steel body
Crema gliera in nylon e corpo in acciaio
Crémaillère en nylon avec corps en acier
Nylon-Zahnstange mit Stahlkörper
Crema gliera de nylon y cuerpo de acero
Зубчатая рейка из нейлона и корпус из нержавеющей стали



CODE	ART.	Size	Box info	
			Pcs per pack	Kg
11400102	261-26x20	L=1000	1	1.10

Finishing: Galvanized / Zincato

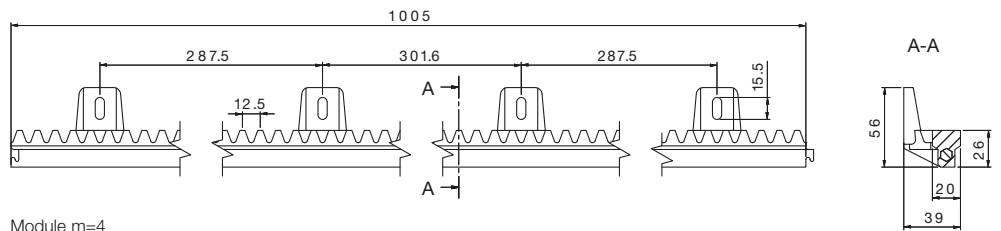

Module m=4

BULLET

264

Support for rectangular rack to be welded
Attacco a saldare per crema gliera rettangolare
Attache entretoise pour crémaillère rectangulaire
Distanzstück für rechteckige Zahnstange zum Schweißen
Fijación para soldar para crema gliera rectangular
Привариваемое соединение для прямоугольной зубчатой рейки



CODE	ART.	Box info	
		Pcs per pack	Kg
11401505 001	264	30	1.50

Finishing: Galvanized / Zincato

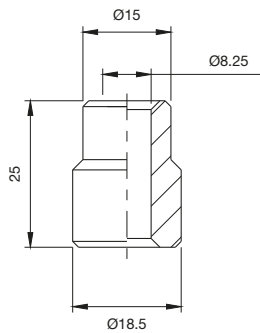

266

Alloy support for rectangular rack
Attacco in zama per crema gliera rettangolare
Attache entretoise en zamak pour crémaillère rectangulaire
Zamak-Distanzstück für rechteckige Zahnstange
Fijación de zamak para crema gliera rectangular
Соединение из сплава зата для прямоугольной зубчатой рейки



CODE	ART.	Box info	
		Pcs per pack	Kg
11402505 001	266	30	2.10

Finishing: Galvanized / Zincato

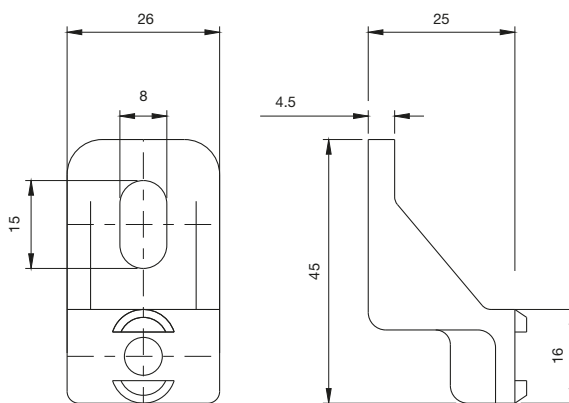

Compatible Cantilever Accessories

CGS-346

Bottom end cup to be fixed

Incontro inferiore a fissare

Butée inférieure à fixer

Unterauflageschuh zum Aufschrauben

Encuentro inferior para fijar

Прикрепляемый нижний упор



CODE	ART.	Size	A	B	C	D	E	F	G	H	I	S	Box info	
													Pcs per pack	Kg
10705501 001	CGS-346M	Mini	104	78	25	9	75	114	25	91	38	4	2	2.3
10705505 001	CGS-346P	Piccolo	119	112	30	11	84	154	33	112	50	4	2	3.6

Finishing: Galvanized / Zincato

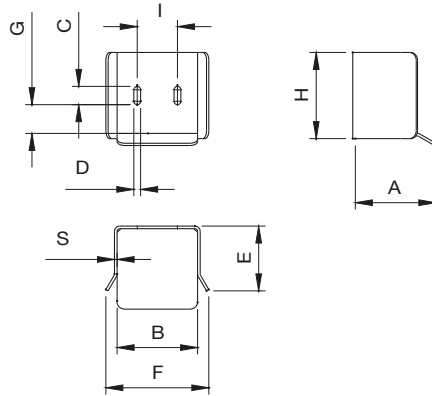

CG-15

Adjustable wall mounting angle racket for end cup

Staffa angolare regolabile fissaggio a

muro per incontro

Platine angulaire réglable fixation au mur pour butée

Verstellbare Eckmuerhalterung für Auflageschuh

Placa angular regulable fijación a la pared para

encuentro

Угловой регулируемый кронштейн крепления

к стене для упора



CODE	ART.	A	B	C	D	E	F	H	I	S	Box info	
											Pcs per pack	Kg
10708001 001	CG-15M	155	110	65	Ø 9.5	9	78	165	64	5	1	2.60
10708005 001	CG-15P	155	110	80	Ø 9.5	11	90	190	64	5	1	2.90

Finishing: Galvanized / Zincato

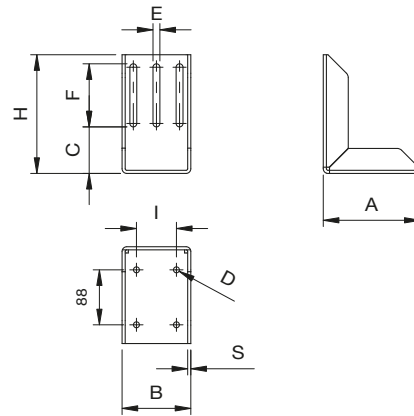

CGS-347

End wheel for monorail

Ruota terminale per monorotaia

Galet d'extrémité pour rail

Endrad für Einfachschiene

Rueda terminal para monorail

Концевое колесо монорельса



CODE	ART.	A	B	C	D	E	F	G	H	L	M	N	S	Box info	
														Pcs per pack	Kg
10705001 001	CGS-347M	135	68	82.5	Ø 68	123	12	14.5	68	45	32	15	4	2	2.00
10705005 001	CGS-347P	141	100	104	Ø 78	129	12	15	89	66	37	20	4	2	3.40

Finishing: Galvanized / Zincato

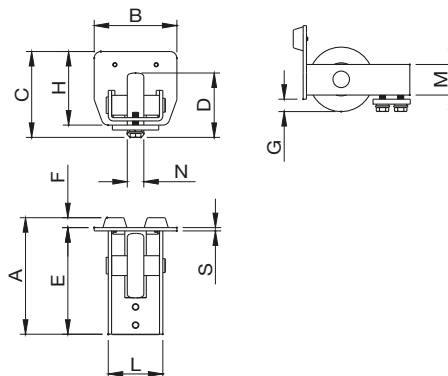

CG-20

End stopper without wheel for monorail

Terminale senza ruota per monorotaia

Embout d'extrémité sans galet pour rail

Endpfropfen für Einfachschiene ohne Rad

Terminal sin rueda para monocarril

Наконечник без колеса для монорельса



CODE	ART.	Size	A	B	C	E	F	H	S	Box info	
										Pcs per pack	Kg
10707101 001	CG-20M	Mini	68	68	78	155	12	68	4	2	1.20
10707105 001	CG-20P	Piccolo	100	100	105	155	12	89	4	2	1.80

Finishing: Galvanized / Zincato

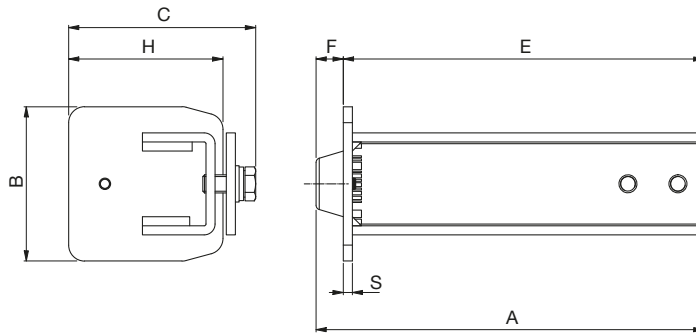

CG-21

End stopper without wheel for monorail

Terminale senza ruota per monorotaia

Embout d'extrémité sans galet pour rail

Endpfropfen für Einfachschiene ohne Rad

Terminal sin rueda para monocarril

Наконечник без колеса для монорельса



CODE	ART.	Size	A	B	C	Box info	
						Pcs per pack	Kg
10707115 001	CG-21M	Mini	68	68	49	4	1.30
10707120 001	CG-21P	Piccolo	100	89	50	4	1.70

Finishing: Galvanized / Zincato

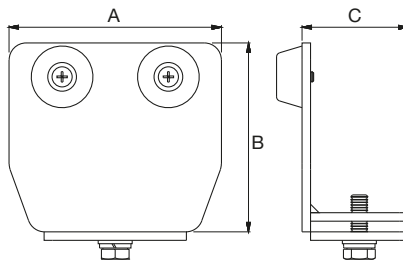

CG-40

Tension bar for gate regulation

Tirante in acciaio zincato per regolazioni

cancelli

Tirants pour réglage portails

Ankerbolzen zur Torregulierung

Tensores de acero galvanizado para regulaciones puertas

Тяга из оцинкованной стали для регулирования ворот

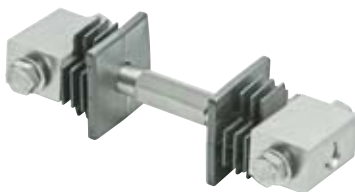

CODE	ART.	R		Box info	
				Pcs per pack	Kg
10131400 001	CG-40	50-100	19	1	1.30

Finishing: Galvanized / Zincato

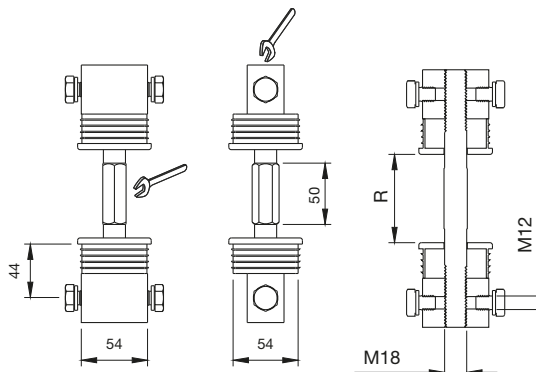

Compatible Cantilever Accessories

CG-25

Lower end cup with nylon roller

Incontro inferiore con rullo in nylon

Butée inférieure avec rouleau en nylon

Unterauflageschuh mit Nylonrolle

Encuentro inferior con rodillo de nylon

Нижний упор с нейлоновый роликом



CODE	ART.	Size	A	B	D	F	H	I	S	Box info	
										Pcs per pack	Kg
10707501 001	CG-25M	Mini	80	40	∅ 50	8.5	115	45	5	2	1.30
10707505 001	CG-25P	Piccolo	122	50	∅ 60	11	130	75	5	2	2.60

Finishing: Galvanized / Zincato

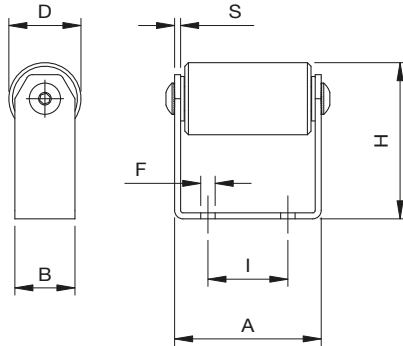

CG-30

Adjustable end cup to be fixed for gates

Incontro per cancelli regolabile a fissare

Butée réglable à fixer pour portails

Verstellbarer Auflageschuh zum Aufschrauben für Tore

Encuentro para puertas regulable para fijar

Прикрепляемый упор для ворот регулируемый



CODE	ART.	Size	R	Box info	
				Pcs per pack	Kg
10707601 001	CG-30M	Mini	53-76	1	1.50
10707605 001	CG-30P	Piccolo	86-114	1	1.90

Finishing: Galvanized / Zincato

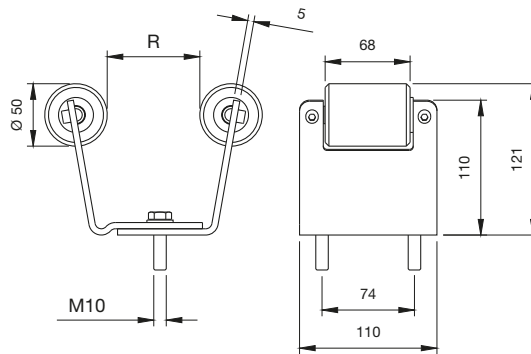

CG-35

Intermediate support with nylon roller

Supporto intermedio di sostegno con rullo

in nylon

Support intermédiaire de soutien avec rouleau en nylon

Mittlerer Stütze für selbsttragende Tore

Soporte intermedio de sostén con rodillo de nylon

Промежуточная опора с нейлоновый роликом



CODE	ART.	A	B	D	F	H	I	S	Box info	
									Pcs per pack	Kg
10707705 001	CG-35P	122	80	∅ 60	17	95	70	5	1	1.40

Finishing: Galvanized / Zincato

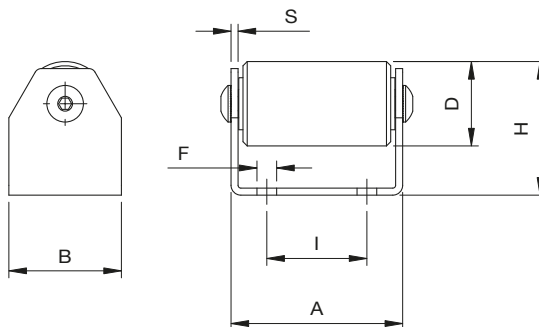

CG-251

Adjustable gate guide plate to be fixed with long wing

Plastra guida cancello regolabile con ala lunga a fissare

Plaque guide portail réglable à fixer avec aile longue

Verstellbare Torführungsplatte mit langem Flügel zum Aufschrauben

Placa de guía de la puerta regulable con ala larga para fijar

Пластина регулируемая направляющая ворот с длинной приклепываемой полкой



CODE	ART.	A	C	D	G	H	I	L	M	R	Box info	
											Pcs per pack	Kg
11310005 001	CG-251	74	58	Ø40	190	154	230	350	44-88	70-110	1	6.70

Finishing: Galvanized / Zincato

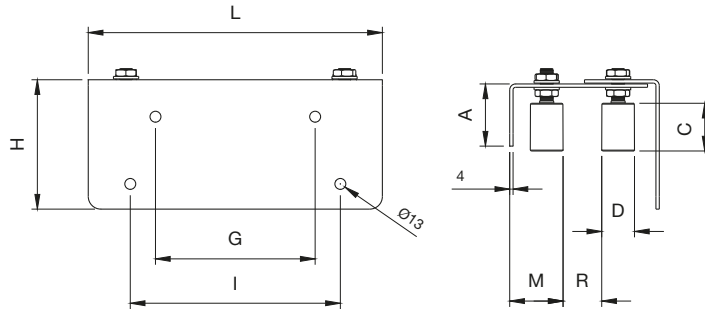

232

Nylon roller with accident prevention

Oliva in nylon con protezione

antifortunistica

Rouleau en nylon pour la prévention des accidents

Nylon-Führungsrolle für die Unfallverhütung

Rodillo de nylon con protección

Нейлоновый наконечник с защитой от несчастных случаев



CODE	ART.	A	B	D	I	H	Box info	
							Pcs per pack	Kg
11302210 001	232-30	40	Ø30	3	84	24	20	4.40
11302215 001	232-40	58	Ø39	7.5	98	24	20	5.90

Finishing: Galvanized / Zincato

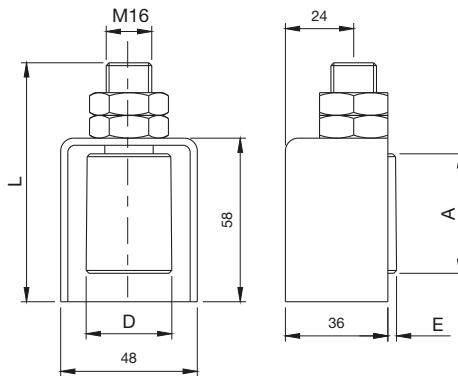

252

Double adjustment plate to be screwed for gates with 2 columns

Plastra doppia regolazione a fissare per

cancelli con doppia colonna

Platine double réglage à visser pour portails avec 2 colonnes

Platte zum Anschrauben mit Doppelverstellung für Tore mit zwei Pfeiler

Placa doble regulación para fijar para puertas con dos columnas

Приклепываемая пластина с двойным регулированием для ворот с двумя стойками



CODE	ART.	Size	E	R	Box info	
					Pcs per pack	Kg
11306205 001	252-200	Ø 40	210-360	0-300	1	4.1

Finishing: Galvanized / Zincato

